



SANY
AMERICA INC.

SRC865

Rough Terrain Crane



- 65 U.S. Tons (59 Metric Tons) @ 10 ft Radius
- 113 ft, 4 Section Main Boom
- 30.2 ft – 52.5 ft Boom Extension

Product Guide

OPERATOR'S CAB



Spacious ergonomic cab with all steel construction. Optimum visibility, tinted safety glass through. Opening skylight with visor and wiper system. Sliding door on the left hand side and a framed sliding window on the right hand side. Acoustical foam to absorb noise and insulate the cab. Deluxe six-way adjustable seat is equipped with mechanical suspension and includes arm rests and head rest.

SANY DESIGNED LMI

The user friendly SANY designed LMI is prominently displayed and simple to set up and operate. The console also features large TV monitors.



HIGH QUALITY, NAME BRAND COMPONENTS



Cummins engine coupled to **Parker & Husco** hydraulic components deliver high reliability and consistent performance.

SRC865



- Engine: Cummins Model QSB6.7 250 HP @ 2500 rpm
- Hydraulic system Parker Piston Pumps and Husco Valves
- Braden winch
- SANY designed LML with large display screen
- AxleTech Axles and Dana Powershift Transmission
- 113 Foot Four Section Main Boom and 30.2' – 52.5' Extension
- Key standard features
 - Large Cab
 - Horsepower Limited Pumps
 - Hydraulic Joystick Controls
 - Post Compensated Valves
 - SANY 24 Volt Electrical Control System

Maximum Capacity @ Radius	65 US Ton @ 10 ft
Main Boom	37 ft – 113 ft
Max Tip Height w/Extension	174.1 ft
Boom Extension	30.2 ft – 52.5 ft
Hoist Max Line Pull	18,210 lb
Wire Rope Diameter	3/4 in
Weight	89,760 lb
Length	45 ft 1.5 in
Height	12 ft 4.5 in
Width	10 ft 10 in
Max Gradeability	142% GVW
Tail Swing	13 ft 10 in

ENGINE

Cummins Model QSB6.7 Tier 3
 Power..... 250 HP (186.4 Kw)
 Fuel Tank 90 Gal. (340L)



SWING SYSTEM

The swing system can rotate 360 degrees continuously in both directions. Independent swing circuit eliminates function interaction. Planetary drive offers free swing or automatic brake application for operator preference. Maximum speed 2.5 RPM with a 13ft 10 in. tailswing.



HYDRAULIC SYSTEM

Parker horsepower limited piston pumps with Husco post compensated valves provides multifunction load sharing and fine control. Energy saving system offers a lower operational cost. Oil cooler and pressure filter to ensure long component life.



HOISTS

Braden main and auxiliary hoists are independently driven and controlled by the joysticks.

Rope Diameter 3/4"
 Max Line Speed 492 ft/min
 Max Line Pull 18,210 lbs
 Drum Capacity 906 ft



CONTROLS

Pilot operated, hydraulic joysticks produce smooth variable control of crane functions. Drum rotation indicators are incorporated in the handles. Steering column mounted turn signals and transmission control. Foot pedals for swing brake, telescope, service brake and accelerator. Hi-Low hoist speed control switch in handle for ease of use. SANY electrical system includes LML and lockout with CAN bus for reduced complexity. Built in diagnostics and engine instrumentation display. Electrical system is 24 volt.



COUNTERWEIGHT

Bolt on 9,969 pound counterweight.



OPERATOR'S CAB

Spacious ergonomic cab with all steel construction. Optimum visibility, tinted safety glass throughout. Opening skylight with visor and wiper system. Sliding door on the left hand side and a framed sliding window on the right hand side. Acoustical foam to absorb noise and insulate the cab. Deluxe six-way adjustable seat is equipped with mechanical suspension and includes arm rests and head rest.



CARRIER

Equipped with 4x4 hydraulic powered steering for excellent maneuverability. Three position outriggers provide 14" of ground penetration and 23.6 ft of extension to level the crane. Superior accessibility from ground for ease of maintenance. Earthmover style 29.5 X 25 (28 PR) tires provide excellent flotation for off road use. Dana powershift transmission includes 6 speeds forward and reverse with a maximum speed of 25 MPH. AxleTech drive steer axles are supplied with hydraulic disk brakes and a spring applied parking brake.

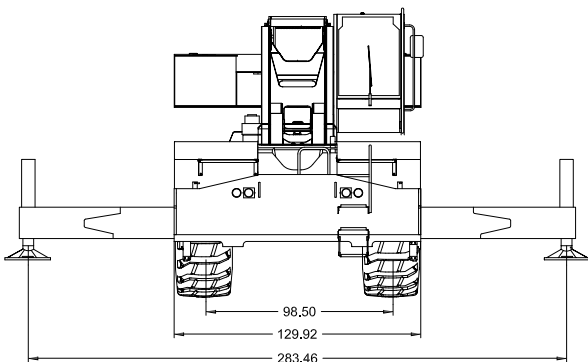

BOOM

Four section sequenced synchronized full power boom.

(37' - 113') Boom elevation -2° to 78° with a maximum tip height of 121.3 ft. Side mounted bifold boom extension (30.2' - 52.5') with 0°, 15°, and 30° offset. Maximum tip height of 174.1 ft.

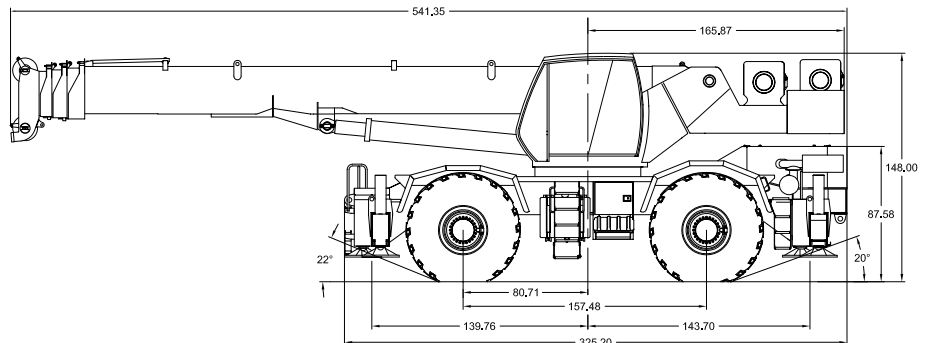

Anti-Two-Block (A2B)

A limit switch and an actuation weight on load lines are provided to prevent two-blocking of the hook block and the overhaul ball. When the lifting hook reaches its maximum height, a limit switch will activate the buzzer on the control panel, meanwhile the indicator light will blink and automatically stop the lifting operation of hook block.

Backup Alarm

A backup alarm will operate when the machine is placed in reverse.

Crane Level Indicator

A bubble level displaying the machine angle is mounted in the operators cab.

Boom Angle Indicator

The boom angle is displayed on the LML console.

Boom Length Indicator

A cable reel is provided to measure the boom length and it is displayed on the LML console.

Load Holding Valves

Load holding valves are provided on all cylinders that support the load to prevent uncontrolled lowering of the boom in the event of a hydraulic system failure (e.g., supply hose rupture).

Load Moment Limiter (LML)

A Load Moment Limiter (LML) system is supplied to monitor the hook load and compare it with the rated load for the configuration selected by the operator.

Outrigger Jack Integral Holding Valve

All four outrigger jacks are supplied with an integral holding valve to prevent cylinder retraction in the event of a hose failure.

Outrigger Position Sensor

Each outrigger beam is supplied with a position sensor to monitor the extension of the outrigger.

Hoist Drum Rotation Indicator

All drums are equipped with an electric drum rotation indicator device that will vibrate the operator's joystick as the drum rotates.

Horn

The crane is supplied with a horn for the operator to warn personnel in the vicinity of the crane..

Drum Brake

All hoist drums are equipped with a spring applied hydraulic released brake. The brake will automatically apply when the control handle returns to neutral.

Function Cut-Out

If the arm rest is raised, all crane functions for operating the superstructure will be deactivated.

Lighting

Equipped with driving lights in front of machine, stop turn & tail lights in the rear of the machine, operator's cab interior light, and a spot light mounted on the front of the cab.

Rearview Mirror

Externally installed on the left of the operator's cab for monitoring the rear of the machine.

Swing Lock

Mechanical pin lock to lock the crane in front positions.

Seat Switch



The operator must be seated for all machine functions to work.

Third Wrap Indicator

A roller riding on the hoist wire rope will actuate a switch to warn the operator when 3 wraps are remaining. The system will sound a buzzer and an alarm indicator will be displayed on the instrument cluster and automatically stop the drum movement.

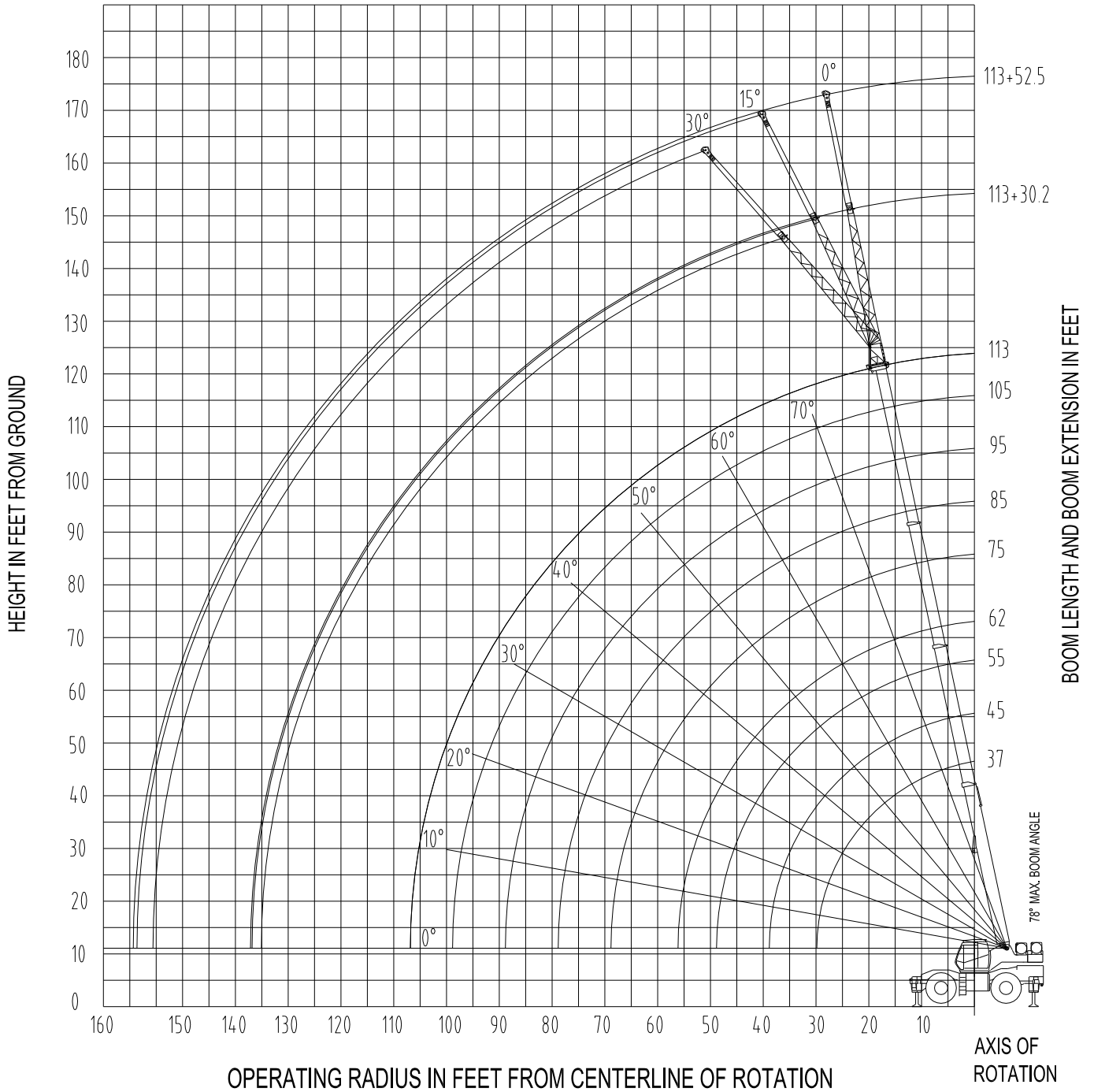
**WORKING RANGE DIAGRAM
(BOOM DEFLECTION NOT SHOWN)
SANY SRC865**



SRC865 MAIN BOOM - ON OUTRIGGERS - FULLY EXTENDED, 360°									
	 Main Boom	 Outriggers Fully Extended	 360°						
RADIUS FT	Boom Length - Feet								
	37	45	55	62	75	85	95	105	113
10	130000	86170	81700						
12	100260	86170	81700	64260					
15	86310	83530	81240	61830	37580	37140	31540		
20	66660	66250	65140	51470	37580	37140	31540		
25	49160	53240	52460	42650	37140	34170	30370	27220	24470
30	41160	38000	38190	35380	33480	29210	25990	24580	22390
35		29990	29970	27700	28960	25500	22580	22310	20390
40			22790	22760	24600	22260	20230	19290	18840
45			17780	17750	19470	18600	17960	17520	17410
50				14060	15700	16640	15780	16130	15430
55				11230	12800	13710	14420	14480	13910
60					10510	11380	12080	12640	12500
65					8650	9500	10170	10720	11090
70						7940	8600	9130	9490
75						6630	7270	7790	8140
80							6140	6650	7000
85							5170	5670	6010
90								4810	5150
95								4060	4390
100									3720
105									3120
MIN BOOM ANGLE									
Boom Angle	Main Boom Length - Feet								
	37	45	55	62	75	85	95	105	113
0°	40200	24740	15120	10850	7550	5840	4570	3590	2940



SRC865 MAIN BOOM - ON OUTRIGGERS - 50% EXTENDED, 360°



Main Boom



Outriggers 50% Extended



360°

RADIUS FT	Boom Length - Feet								
	37	45	55	62	75	85	95	105	113
10	109450	86170	81700						
12	99310	86170	81700	64260					
15	80290	83530	81240	61830	37580	37140	31540		
20	48170	48170	48150	48130	37580	37140	31540		
25	30590	30570	30540	30510	32640	32120	30370	27220	24470
30	21080	21050	21010	20980	22890	23990	23720	24580	22390
35		15080	15040	15000	16770	17800	18600	19250	19700
40			10940	10910	12580	13550	14310	14930	15350
45			7970	7930	9530	10460	11190	11780	12180
50				5660	7210	8110	8810	9380	9770
55				3880	5390	6260	6940	7500	7870
60					3920	4770	5440	5980	6340
65					2710	3540	4190	4720	5080
70						2510	3150	3670	4030
75						1640	2270	2780	3130
80							1510	2020	2360
85							850	1350	1690
90									1100
MIN BOOM ANGLE							10°	21°	28°

Boom Angle	Main Boom Length - Feet					
	37	45	55	62	75	85
0°	20590	12120	6350	3650	1990	1110

SRC865 MAIN BOOM - ON OUTRIGGERS RETRACTED, 360°



Main Boom





Outriggers Retracted



360°

RADIUS FT	Boom Length - Feet								
	37	45	55	62	75	85	95	105	113
10	91460	86170	81700						
12	61840	61840	61830	61820					
15	39820	39810	39790	39760	37580	37140	31540		
20	22820	22790	22750	22720	24750	25910	26840		
25	14350	14320	14280	14240	16050	17090	17920	18580	19040
30	9300	9250	9200	9170	10850	11810	12580	13190	13610
35		5890	5830	5790	7380	8300	9020	9610	10010
40			3420	3380	4910	5790	6490	7050	7430
45			1620	1580	3060	3920	4590	5130	5500
50					1620	2460	3110	3640	4000
55						1290	1930	2450	2800
60							970	1480	1820
65									1010
MIN BOOM ANGLE			0°	32°	38°	44°	46°	48°	5°



Boom Angle	Main Boom Length - Feet	
	37	45
0°	9040	4160

SRC865 MAIN BOOM - LOAD STATIONARY, ON TIRES, 360°					
 Stationary On Tires  360°					
RADIUS FT	Boom Length - Feet				
	37	45	55	62	75
10	36780	36740	36680		
12	30270	30230	30170	30130	
15	22180	22170	22140	22120	23980
20	12680	12660	12630	12600	14200
25	7590	7560	7530	7500	8950
30	4430	4390	4350	4310	5690
35		2220	2180	2140	3450
40					1830
MIN BOOM ANGLE			35	44	49

Boom Angle	Main Boom Length - Feet	
	37	45
0°	4260	1100

NOTES TO ALL ON TIRE CAPACITY CHARTS:

1. Capacities are in pounds and do not exceed 75% of tipping loads as tested in accordance with SAE J765.
2. Capacities are applicable to machines equipped with 29.5R25 - ** Bridgestone radial tires at 75 psi cold inflation pressure.
3. Capacities appearing above the bold line are based on structural strength and tipping should not be relied upon as a capacity limitation.
4. Capacities are applicable only with machine on firm level surface.
5. On tire lifting with the boom extensions is not permitted.
6. For pick and carry operation, boom must be centered over the front of the machine with the swing lock engaged and the load restrained from swinging.
7. Axle lockouts must be functioning when lifting on tires.
8. All lifting depends on proper tire inflation, capacity and condition. Capacities must be reduced for lower tire inflation pressures. See lifting capacity information for tire used. Damaged tires are hazardous to safe operation of crane.

SRC865 MAIN BOOM - LOAD STATIONARY, OVER FRONT TIRES, 360°					
 Stationary On Tires  Over Front Tires					
RADIUS FT	Boom Length - Feet				
	37	45	55	62	75
10	55830	55790	55720		
12	47970	47920	47860	47810	
15	39070	39020	38960	38910	40320
20	28930	28870	28810	28760	30160
25	22130	22070	22010	21960	23340
30	15410	15380	15340	15320	16880
35		11010	10970	10940	12410
40			7920	7890	9280
45			5670	5630	6970
50				3900	5190
55				2530	3790
60					2650
65					1700
MIN BOOM ANGLE					



Boom Angle	Main Boom Length - Feet				
	37	45	55	62	75
0°	15050	8810	4430	2350	1140

SRC865 MAIN BOOM - LOAD PICK & CARRY ON TIRES					
Pick & Carry On Tires  Over Front Tires					
RADIUS FT	Boom Length - Feet				
	37	45	55	62	75
10	44790	44740	44680		
12	38200	38150	38090	38040	
15	30740	30690	30630	30580	31990
20	22240	22190	22120	22080	23470
25	16550	16490	16420	16370	17760
30	12480	12410	12340	12280	13660
35		9340	9260	9210	10580
40			6870	6820	8180
45			4960	4900	6260
50				3340	4680
55				2040	3370
60					2260
65					1310
MIN BOOM ANGLE					

Boom Angle	Main Boom Length - Feet				
	37	45	55	62	75
0°	12260	7650	3860	1870	740

Number in parentheses () is the Boom Angle in Degrees.

* This rated load is with the boom at the maximum boom angle.

SRC865 - BOOM EXTENSION, ON OUTRIGGERS - FULLY EXTENDED, 360°												
	 Boom Extension				 Outriggers Fully Extended				 360°			
Radius Feet	30.2 Feet						52.5 Feet					
	Offset Angle						Offset Angle					
	0°		15°		30°		0°		15°		30°	
	Lbs	Deg	Lbs	Deg	Lbs	Deg	Lbs	Deg	Lbs	Deg	Lbs	Deg
35	13000											
40	13000		11170				8570					
45	13000		10760		7630		8570					
50	12400		10300		7410		8570					
55	11300		9490		7200		8400		5450			
60	10300		8800		7000		7850		5300			
65	9400		8160		6850		7370		5250		3970	
70	8710		7600		6680		7000		5100		3900	
75	8070		7100		6560		6480		4940		3760	
80	7440		6660		6290		5980		4750		3650	
85	6630		6250		5950		5530		4600		3550	
90	5770		5890		5640		5120		4400		3510	
95	5000		5350		5350		4760		4150		3400	
100	4330		4640		4850		4440		3940		3350	
105	3730		4000		4180		4160		3720		3310	
110	3090		3420		3560		3710		3510		3270	
115	5710		2900		3010		3220		3320		3150	
120	2270		2430		2490		2770		3140		3020	
125	1870		1990				2370		2720		2880	
130	1510		1590				1990		2300		2510	
135	1190						1650		1920		2080	
140							1340		1560		1670	
145									1230			
Min Boom Angle No Load	7°		15°		30°		20°		23°		30°	

* This rated load is with the boom at the maximum boom angle.

WARNING: Operation of this machine with heavier loads than the capacities listed is strictly prohibited. Machine tipping with boom extension occurs rapidly and without advance warning.

- Capacities above the bold line are based on the structural strength of the boom extension.
- The capacities listed are with the outriggers fully extended and vertical jacks properly set only.
- The boom extension may only be used for single line lifting service.
- Use only the load which corresponds to the boom extension length and offset angle as the machine is configured.
- For main boom lengths less than fully extended with the boom extension erected, the boom extension rated loads are determined by the boom angle not the radius.
- For boom angles not shown, use the rating of the next lower boom angle.
- The boom angle is defined as the angle above or below the horizontal line of the longitudinal axis of the boom base section after lifting the rated load.
- When lifting over the main boom nose with the boom extension erected, the outriggers must be fully extended and the proper load reduction must be used.
- Do not lower the boom below the Minimum Boom Angle with the extension erected. Fully retract the boom to lower the boom below the Minimum Boom Angle.



SANY
AMERICA INC.

318 Cooper Circle
Peachtree City, GA 30269
Tel: 678-251-2810
Fax: 770-632-7820